

Modbus™ Flex I/O Module

Cat. No. A8332

Quick Start Guide

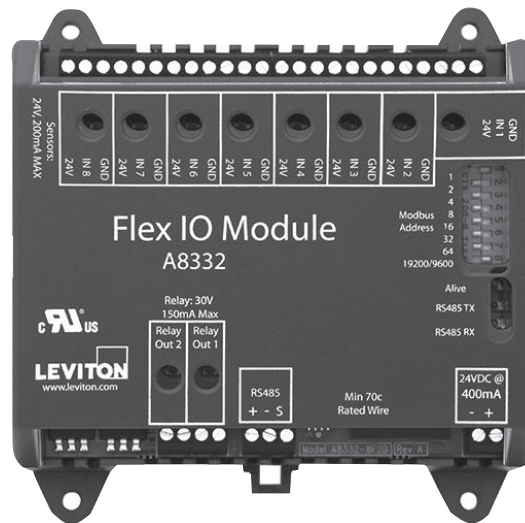

1 PRODUCT APPLICATION LIMITATION

- Leviton products are not intended for use in critical applications such as nuclear facilities, human implantable devices or life support. Leviton is not liable, in whole or in part, for any claims or damages arising from such uses.
- Leviton strongly believes in continuous improvement, therefore we must reserve the right to change specifications and product offerings without notice. Where possible, we will substitute products with equivalent functionality when necessary.

NOTICE
This product is not intended for life safety applications.
Do not install this product in hazardous or classified locations.
The installer is responsible for conformance to all applicable codes.

2 INSTALLATION CHECKLIST

2.1 Configuration Software Required

The A8332 (Flex I/O Module) requires configuration before it may be used. This guide will cover two primary ways to achieve this. (Consult A8332 manual for third party software or hardware integration.)

2.1.1 Obvius Configuration Console: The Obvius Configuration Console (OCC) is a software application designed to assist in the setup and commissioning of Obvius hardware products. The OCC software is available for free download at http://www.obvius.com/Products/Configuration_Console.

2.1.2 Energy Monitoring Hub users may use the integrated web browser interface to set up and configure the A8332 (Flex I/O).

2.2 Modbus Address

Before the Flex I/O can be used, select a Modbus address for the Flex I/O. This address must be unique among all Modbus devices in the system. The A8332 supports address 1 through 127.

Select an address, and set the DIP switches to match.

The sum of the value of the switches is the address. In the example to the right, address 52 is set by placing switch 4, 16 and 32 to the on position.

Note: $4 + 16 + 32 = 52$

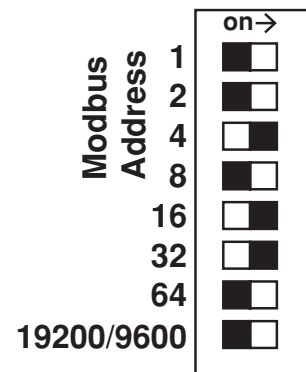

3.1 Installation

3.1.1 Connect the power supply to the input terminals on the A8332 module.

3.1.2 Attach the RS485 +, - and shield wires to the A8332 module. Attach the other end of the RS485 line to the Modbus master device, such as an EMB Hub. Be careful to observe polarity on both ends of the RS485 connection. RS485 wiring runs should be limited to 4000 ft.

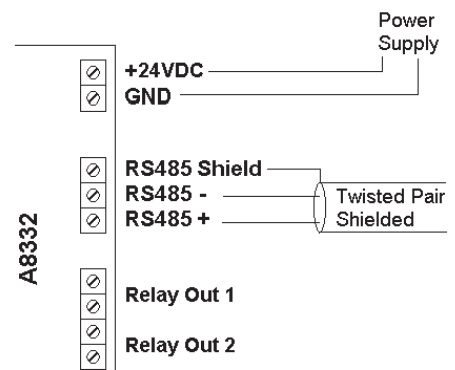

3 INSTALLATION

3.2 Adding Meters and Sensors

- 3.2.1 Turn on the power supply. Confirm the green Alive LED is blinking about once per second. Disconnect the power supply.
- 3.2.2 Verify that the device is recognized by LCC or the EMB Hub.
- 3.2.3 Disconnect the power. Attach the pulse or analog input lines to the pulse terminals. Each input has a GND, Input#, and +24V terminal.

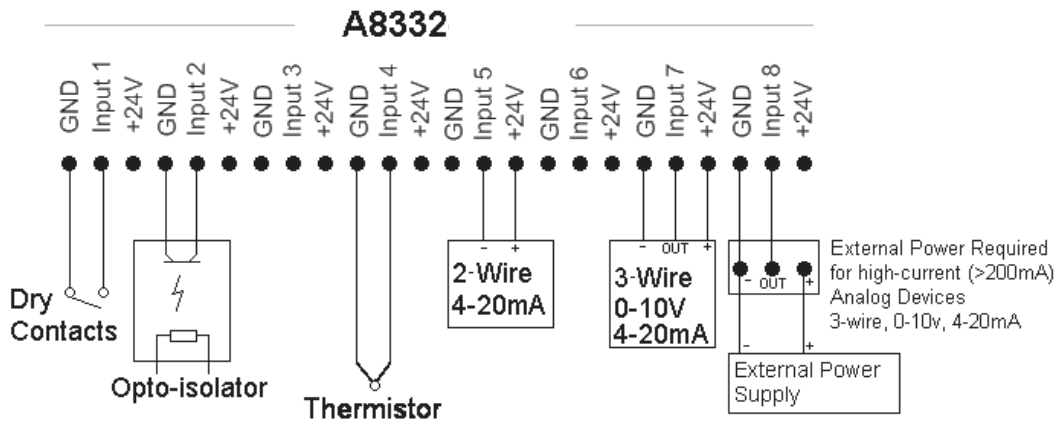

3.3 Powering up the Device

- 3.3.1 Reconnect power to the device. The green “Alive” LED should start to blink approximately once per second.
- 3.3.2 The yellow RS485 TX and RX LEDs will blink for local Modbus activity.
- 3.3.3 For each input, you MUST configure the input mode register. The mode register sets up the input for 4-20mA, 0-10V, pulse, or resistance type sensors. The default mode is “unconfigured”. (Choose only one method below)
 - 3.3.3.1 On the EMB Hub device configuration page, select configure point. Pick the appropriate mode from the dropdown list. You will need to configure each pulse input with a Name, Engineering Unit, and Multiplier.
 - 3.3.3.2 Using the Obvius Config Console software, select the A8332 from the list, and choose the input mode from the dropdown list. Be sure to click the “Save” button at the bottom of the page.
- 3.3.4 After configuring the input mode, the red input status LEDs will show information for each input depending on the configured mode of the input. Input status LEDs are adjacent to the corresponding input screw terminals.
- 3.3.5 For inputs configured for pulse, pulse-kyz, and status, the LED will turn on when the contact is closed.
- 3.3.6 For 4-20mA, 0-10V modes, the LED will show off-scale-high by blinking fast (2x second)
- 3.3.7 For 4-20mA and Resistance mode, the LED will show a broken wire alarm with a blink-blink-off pattern.
- 3.3.8 For unconfigured inputs, the LED will be off.

4 WARRANTY AND CONTACT INFORMATION

FCC STATEMENT:

This equipment has been tested and found to comply with the limits for a Class A digital device, pursuant to part 15 of the FCC Rules. These limits are designed to provide reasonable protection against harmful interference when the equipment is operated in a commercial environment. This equipment generates, uses, and can radiate radio frequency energy and, if not installed and used in accordance with the instruction manual, may cause harmful interference to radio communications. Operation of this equipment in a residential area is likely to cause harmful interference in which case the user will be required to correct the interference at his own expense.

Any changes or modifications not expressly approved by Leviton Manufacturing Co., could void the user's authority to operate the equipment

TRADEMARK DISCLAIMER:

Use herein of third party trademarks, service marks, trade names, brand names and/or product names are for informational purposes only, are/may be the trademarks of their respective owners; such use is not meant to imply affiliation, sponsorship, or endorsement. EMB Hub is a trademark of Leviton Manufacturing Co., Inc. Modbus is a U.S. registered trademark of Schneider Electric USA, Inc. Belden is a trademark of Belden, Inc.

FCC SUPPLIERS DECLARATION OF CONFORMITY (SDOC):

Model A8332 manufactured by Leviton Manufacturing Co., Inc., 201 North Service Road, Melville, NY 11747, www.leviton.com. This device complies with part 15 of the FCC Rules. Operation is subject to the following two conditions: (1) This device may not cause harmful interference, and (2) this device must accept any interference received, including interference that may cause undesired operation.

IC STATEMENT:

This device complies with Industry Canada license-exempt RSS standard(s). Operation is subject to the following two conditions: (1) this device may not cause interference, and (2) this device must accept any interference, including interference that may cause undesired operation of the device.

Leviton Manufacturing Co., Inc.

201 North Service Road, Melville, NY 11747

Visit Leviton's Web site at www.leviton.com

© 2021 Leviton Manufacturing Co., Inc. All rights reserved.

Specifications and price subject to change at any time without notice.

FOR CANADA ONLY

For warranty information and/or product returns, residents of Canada should contact Leviton in writing at **Leviton Manufacturing of Canada ULC to the attention of the Quality Assurance Department, 165 Hymus Blvd, Pointe-Claire (Quebec), Canada H9R 1E9 or by telephone at 1 800 405-5320.**

LIMITED 5 YEAR WARRANTY AND EXCLUSIONS

Leviton warrants to the original consumer purchaser and not for the benefit of anyone else that this product at the time of its sale by Leviton is free of defects in materials and workmanship under normal and proper use for five years from the purchase date. Leviton's only obligation is to correct such defects by repair or replacement, at its option. **For details visit www.leviton.com or call 1-800-824-3005.** This warranty excludes and there is disclaimed liability for labor for removal of this product or reinstallation. This warranty is void if this product is installed improperly or in an improper environment, overloaded, misused, opened, abused, or altered in any manner, or is not used under normal operating conditions or not in accordance with any labels or instructions. **There are no other or implied warranties of any kind, including merchantability and fitness for a particular purpose,** but if any implied warranty is required by the applicable jurisdiction, the duration of any such implied warranty, including merchantability and fitness for a particular purpose, is limited to five years. **Leviton is not liable for incidental, indirect, special, or consequential damages, including without limitation, damage to, or loss of use of, any equipment, lost sales or profits or delay or failure to perform this warranty obligation.** The remedies provided herein are the exclusive remedies under this warranty, whether based on contract, tort or otherwise.

For Technical Assistance Call: 1-800-824-3005 (USA Only) or 1-800-405-5320 (Canada Only) www.leviton.com

